

SECTION 05: SPEEDWAY® PRE-GALV. CABLE LADDER SYSTEMS



The Speedway® family is growing.
Speedway® Cable Ladder is now available in Pre-Galvanised Steel (QQ).

The newly added material choice offers greater flexibility, enabling contractors to choose the most suitable material based on the specific requirements of each project.

Featuring the original Speedway® Cable Ladder design benefits including:

- Special Profiled Side Section
- Slotted Side Section
- Shallow Channel Rungs

Manufactured in 3 heights:

- Speedway® 4 (SW4) Pre-Galv. - 100mm overall height
- Speedway® 5 (SW5) Pre-Galv. - 125mm overall height
- Speedway® 6 (SW6) Pre-Galv. - 150mm overall height

Ladder, Fittings, Covers & Accessories

-  Pre-Galvanised Structural Steel (BS EN 10346)

Speedway® Pre-Galvanised Cable Ladder is ideally suited for areas with low levels of atmospheric corrosion. It has been tested in accordance with BS EN 61537.

Identification Markings:

Speedway® Cable Ladder products are stamped with Vantrunk; Vantrunk Ltd. is part of the Unitrunk Group.

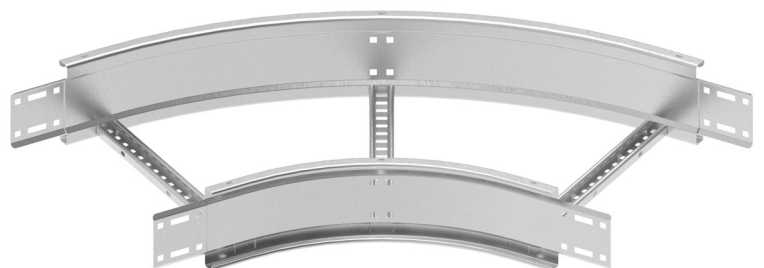

ACCREDITED TO THE FOLLOWING STANDARDS:



Speedway® SW4 Pre-Galvanised Cable Ladder

Speedway® 4 SW4 Pre-Galv. Medium Duty Cable Ladder is manufactured in 3m lengths.

The cable ladder is available in standard widths of 150mm, 300mm, 450mm, 600mm, 750mm, 900mm and 1050mm.

Additional widths are available on request.

Rung spacing is 300mm as standard.

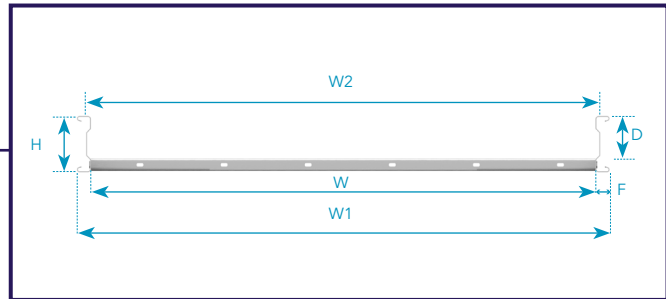
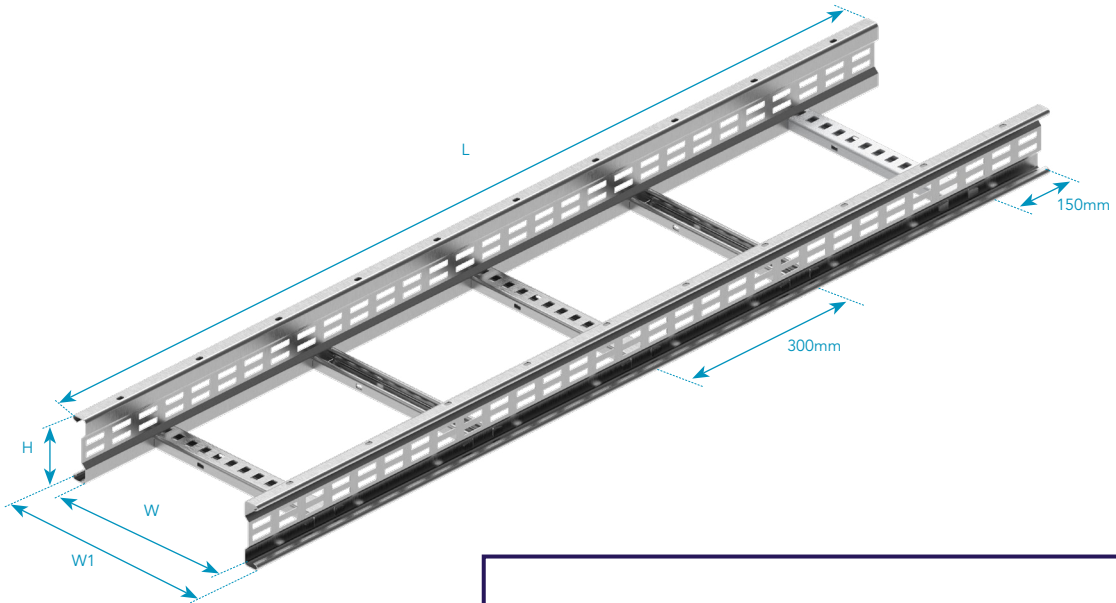

Part Code	No. of Rungs	Dimensions (mm)				Weight (kg)
		W	W1	L	H	
SW4-SL3-150-QQ	10	150	200	3000	100	13.02
SW4-SL3-300-QQ		300	350			14.52
SW4-SL3-450-QQ		450	500			16.12
SW4-SL3-600-QQ		600	650			17.62
SW4-SL3-750-QQ		750	800			19.12
SW4-SL3-900-QQ		900	950			20.62
SW4-SL3-1050-QQ		1050	1100			21.34

Height	H	100mm
Loading Depth	D	75mm
Ladder Width	W	100mm to 1050mm
Overall Width	W1	W + 50mm
Maximum Internal Width	W2	W + 14mm
Flange Width	F	25mm

QuickFix Trunking

QuickFix Multi Compartment Trunking

Lighting Trunking

Unklip Cable Tray

Speedway Cable Ladder Pre-Galv. Cable Ladder

Cable Basket Systems

Channel & Support

Accessories & Supports

Index

SPEEDWAY® PRE-GALV. CABLE LADDER SYSTEMS

Speedway® SW5 Pre-Galvanised Cable Ladder

Speedway® 5 (SW5) Pre-Galv. Heavy Duty Cable Ladder is manufactured in 3m lengths.

The cable ladder is available in standard widths of 150mm, 300mm, 450mm, 600mm, 750mm, 900mm and 1050mm.

Additional widths are available on request.

Rung spacing is 300mm as standard.

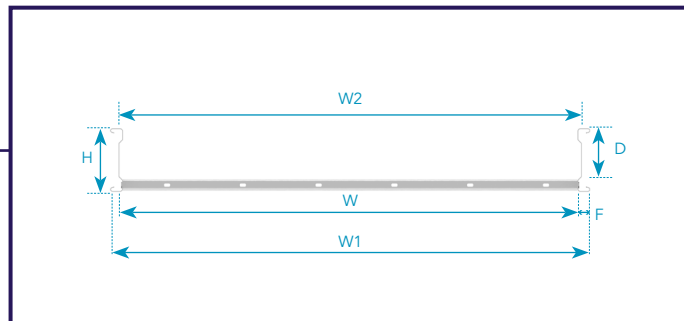
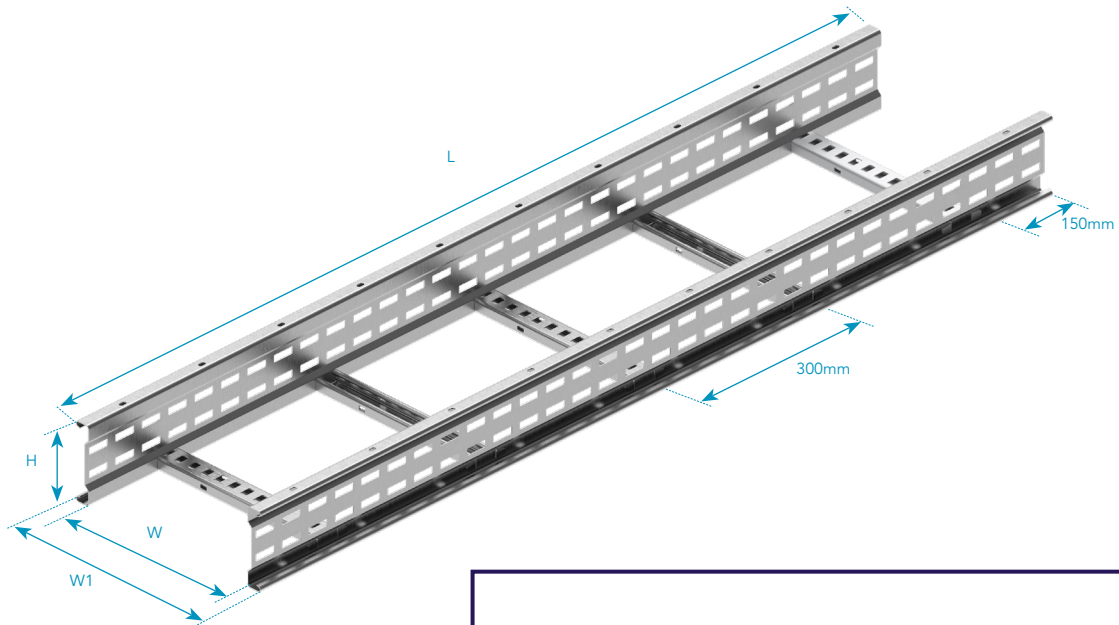

Part Code	No. of Rungs	Dimensions (mm)				Weight (kg)
		W	W1	L	H	
SW5-SL3-150-QQ	10	150	200	3000	125	13.98
SW5-SL3-300-QQ		300	350			15.48
SW5-SL3-450-QQ		450	500			17.08
SW5-SL3-600-QQ		600	650			18.58
SW5-SL3-750-QQ		750	800			20.08
SW5-SL3-900-QQ		900	950			21.58
SW5-SL3-1050-QQ		1050	1100			23.5

Height	H	125mm
Loading Depth	D	100mm
Ladder Width	W	100mm to 1050mm
Overall Width	W1	W + 50mm
Maximum Internal Width	W2	W + 14mm
Flange Width	F	25mm

Speedway® SW6 Pre-Galvanised Cable Ladder

Speedway® 6 (SW6) Pre-Galv. Extra Heavy Duty Cable Ladder is manufactured in 3m lengths.

The cable ladder is available in standard widths of 150mm, 300mm, 450mm, 600mm, 750mm, 900mm and 1050mm.

Additional widths are available on request.

Rung spacing is 300mm as standard.

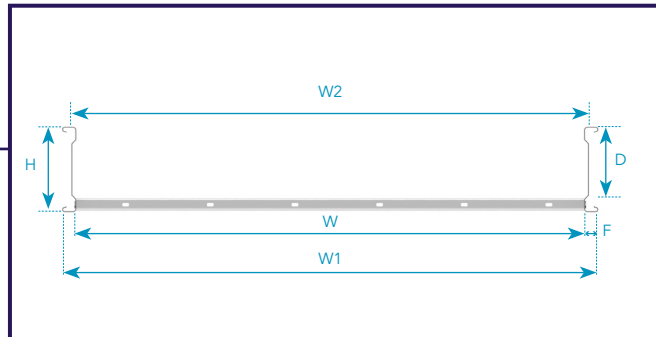
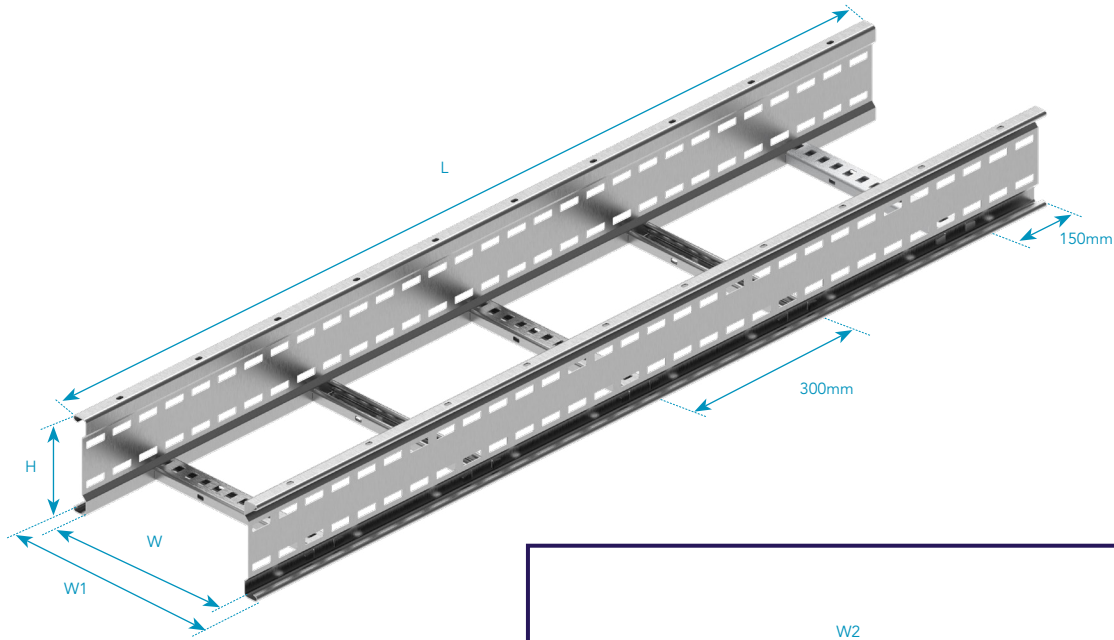

Part Code	No. of Rungs	Dimensions (mm)				Weight (kg)
		W	W1	L	H	
SW6-SL3-150-QQ	10	150	200	3000	150	15.84
SW6-SL3-300-QQ		300	350			17.34
SW6-SL3-450-QQ		450	500			18.94
SW6-SL3-600-QQ		600	650			20.44
SW6-SL3-750-QQ		750	800			21.94
SW6-SL3-900-QQ		900	950			23.44
SW6-SL3-1050-QQ		1050	1100			24.94

Height	H	150mm
Loading Depth	D	125mm
Ladder Width	W	100mm to 1050mm
Overall Width	W1	W + 50mm
Maximum Internal Width	W2	W + 14mm
Flange Width	F	25mm

QuickFix Trunking

QuickFix Multi Compartment Trunking

Lighting Trunking

Unclip Cable Tray

Speedway Cable Ladder Pre-Galv. Cable Ladder

Cable Basket Systems

Channel & Support

Accessories & Supports

Index

SPEEDWAY® PRE-GALV. CABLE LADDER SYSTEMS

Pre-Galvanised Cable Ladder Fitting with Integral Coupler

This fast-fitting system offers significant cost savings through reduction in the number of couplers and fixings required. The integral coupler has a formed shape which increases strength and rigidity, and reduces joint hinging.

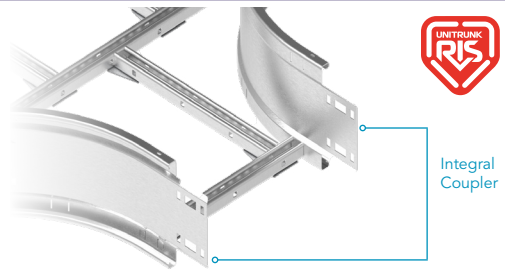

Integral Coupler

Flat Elbow 30°, 45°, 60° & 90°



Part Code

SW△-FE Angle-Width-Radius-QQ

Equal Cross

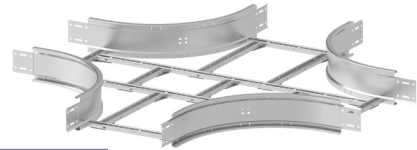

Part Code

SW△-C-Width-Radius-QQ

Equal/Unequal Tee

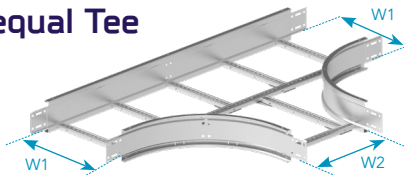

Part Code

Type

SW△-ET-Width-Radius-QQ

Equal

SW△-UT-W1-W2-Radius-QQ

Unequal

Covers

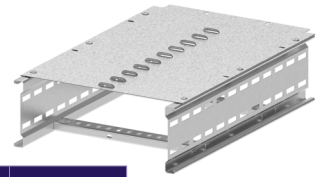

Part Code

Type

SW△-CC-SL1.5-Width-QQ

Closed

SW△-CL-SL1.5-Width-QQ

Louvered

Supplied with fixings. Straight ladder covers are supplied in 1.5m lengths.

Riser (Outside) 30°, 45°, 60° & 90°

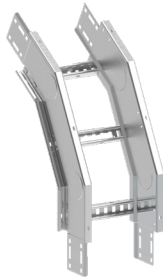

Part Code

SW△-OR Angle-Width-Radius-QQ

Riser (Inside) 30°, 45°, 60° & 90°



Part Code

SW△-IR Angle-Width-Radius-QQ

Straight Coupler

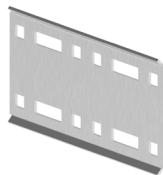

Code

SW△-CS-QQ

Sold in pairs. Supplied with fixings. 1 Pair per ladder.

△ = Select a system type

Long Adjustable Coupler

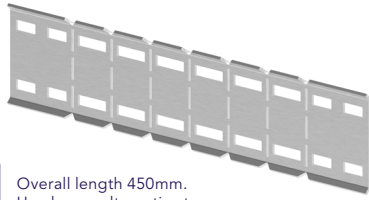

Part Code
SW△-LAC-QQ

Overall length 450mm.
Used as an alternative to Reducers and Unequal Tees.
Supplied with fixings.

Adjustable Fixing Bracket

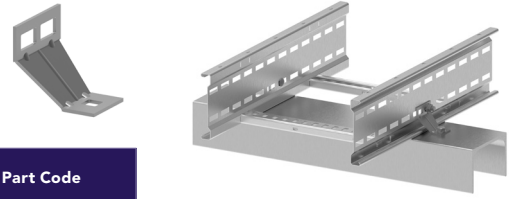

Part Code
SW△-AFB-QQ

Supplied with 1 fixing.

External Flange Clamp

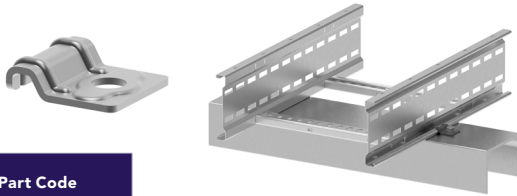

Part Code
SW-EFC-QQ

Fixings ordered separately.

Horizontal Adjustable Coupler

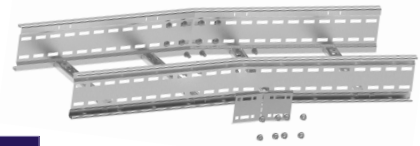

Part Code
SW△-HAC-QQ

Each supplied with fixings.

Hold-Down Bracket

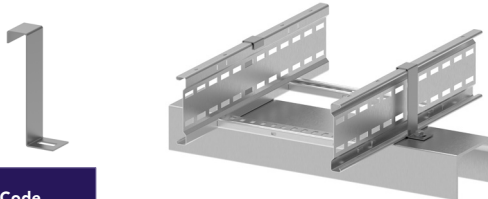

Part Code
SW△-HDB-QQ

Fixings ordered separately.

Vertical Adjustable Coupler

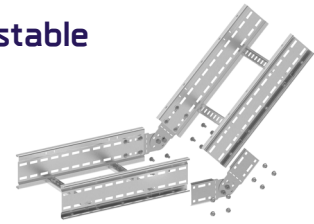

Part Code
SW△-VAC-QQ

Each supplied with fixings.
For SW4 & SW5 order as: SW4-5-vac-finish.
For SW6 order as: SW6-vac-finish.

Straight Ladder Divider



Part Code
SW△-DIV-SL1.5-QQ

Straight ladder dividers are 1.5m long.
Fixings ordered separately.

Straight Reducer

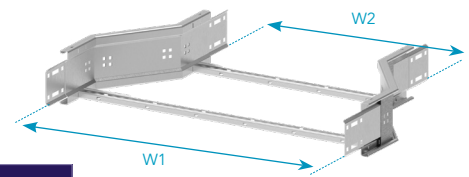

Part Code
SW△-RS-W1-W2-QQ

Reducer Left Hand

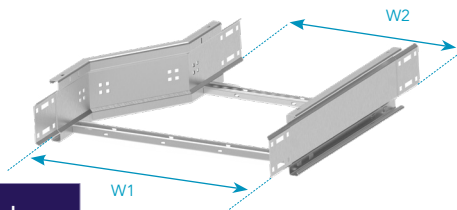

Part Code
SW△-RL-W1-W2-QQ

Reducer Right Hand

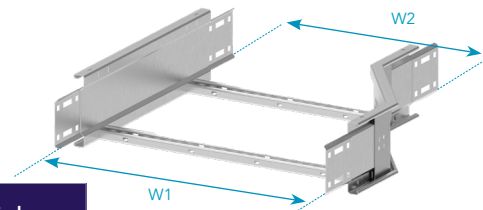

Part Code
SW△-RR-W1-W2-QQ

△ = Select a system type

QuickFix Trunking

QuickFix Multi Compartment Trunking

Lighting Trunking

Unklip Cable Tray

Speedway Cable Ladder Pre-Galv. Cable Ladder

Cable Basket Systems

Channel & Support

Accessories & Supports

Index

SPEEDWAY® PRE-GALV. CABLE LADDER SYSTEMS

Ladder Fixing Kit



Part Code	Description
VSFK-M8-ZD	M8 (suitable for SW4)
VSFK-M10-ZD	M10 (suitable for SW5 & SW6)

Sold in packs of 8.

Earth Braid

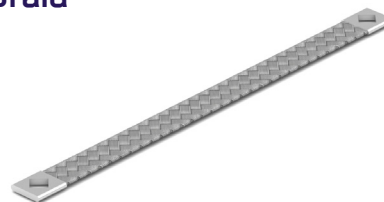

Designed for use in installations where an additional means of earthing or electrical bonding is specified.

Comprised of a 16mm² tinned copper braid crimped into M10 tinned copper end connectors.

The Speedway® Earth Braid/Bonding Strap is compatible with Speedway® SW4, SW5 & SW6.

Part Code	Description
EBS-01	M10 Braid

Standard Material Gauges & Loading Data

Ladder Type	Material & Finish	Sidewall Gauge (mm)	Rung Gauge (mm)						Loading Capacity (kg/m)				
			150	300	450	600	750	900	1.0m span	1.5m span	2.0m span	2.5m span	3.0m span
Speedway® SW4	QQ	1.5	1.5						233	233	233	233	233
Speedway® SW5	QQ	1.5	1.5						234	234	234	234	234
Speedway® SW6	QQ	1.5	1.5						235	235	235	235	235

QQ - Pre-Galvanised Steel

The Speedway® cable ladder system is also available in a combination of side wall gauges (1.5mm & 2.0mm) and rung gauges (1.5mm, 2.0mm, 2.5mm) to suit specific installation requirements.

Consult our Design Team for guidance on the correct selection of material gauge combinations.

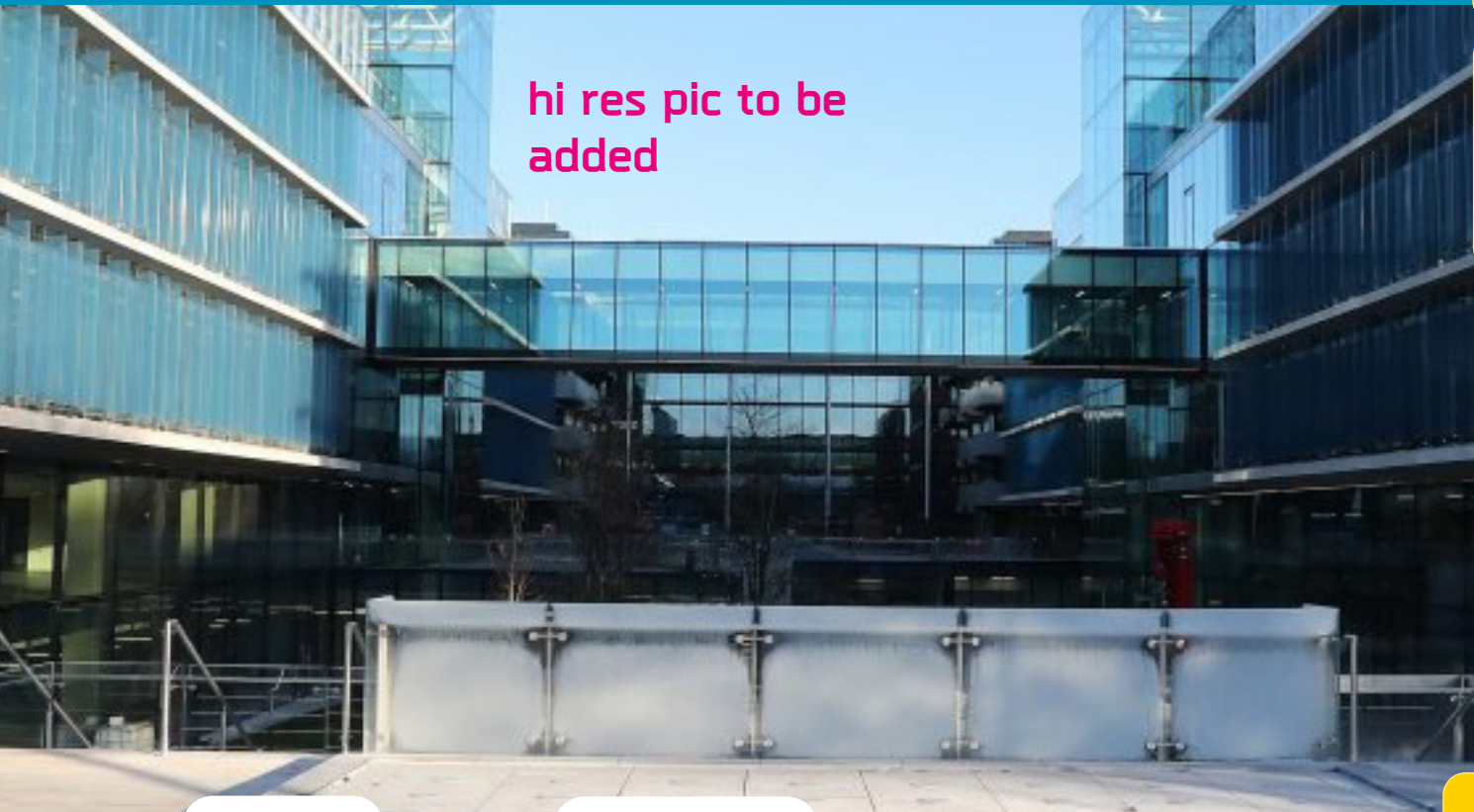

hi res pic to be added

CLIENT



€200M
Total Project Investment

M&E Contractor:



BACKGROUND

Fibonacci Square is the redevelopment of the AIB Bank Centre site in Ballsbridge, Dublin. It consists of two, six-storey office buildings, constructed over three levels of basement. The two buildings sit on existing parklands with a tree-lined perimeter. A glass bridge connects the two office blocks, with a sunken garden plaza in the centre.

PRODUCTS SUPPLIED

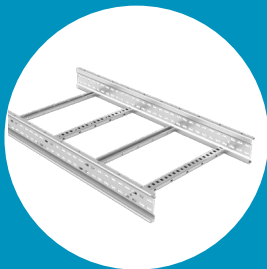

**SPEEDWAY®
LADDER**

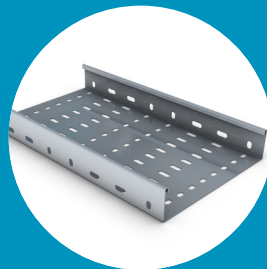

**CABLE
TRAY**



**QUICKFIX
TRUNKING**

Name, Title
Company

- QuickFix Trunking
- QuickFix Multi Compartment Trunking
- Lighting Trunking
- Uniklip Cable Tray
- Speedway Cable Ladder
- Pre-Galv. Cable Ladder
- Cable Basket Systems
- Channel & Support
- Accessories & Supports
- Index